

Single - Out





Single Out Manual

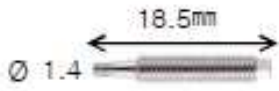
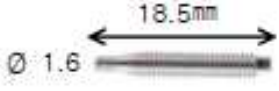
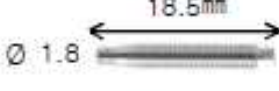
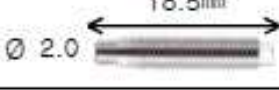
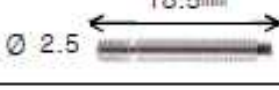

- The Single-out kit provides a new and effective method of atraumatically removing failed implants.

► Component ◀

▷ SCREW : The Screw Connects the implant Fixture With the Fixture Remover.

NO.	Code	Size	Diameter
1	M 1,4		1,4mm
2	M 1,6		1,6mm
3	M 1,8		1,8mm
4	M 2,0		2,0mm
5	M 2,5		2,5mm
6	1-72 UNF		1-72 UNF(1,85)

▷ FIXTURE REMOVER : The Fixture Remover Applies torque through the remover screw to remove the implant.

NO.	Code	Size	Length	Reference
1	FR - 15		15mm (With fixture tip)	
2	FR - 20		20mm (With fixture tip)	

▷ ADAPTER : The Adapter connects the two components of the fixture remover assembly

NO.	Code	Appearance	Diameter
1	AT - 01		5,6mm Ø 5,1(Inside diameter)

▷ FIXTURE TIP : The Fixture tip engages the implant platform.

NO.	Code	Size	Type
1	FT - 38		Narrow
2	FT - 46		Regular
3	FT - 53		Wide Ø 5.0
4	FT - 62		Wide Ø 6.0 ~ 8.0

▷ DRIVER : The Driver tightens the remover screw into the implant fixture

NO.	Code	Size	Length to fix
1	DV-5		5mm
2	DV-11		11mm
3	DV-16		16mm

▷ TORQUE WRENCH : The Torque wrench tightens clockwise or counterclockwise 50–450Ncm

NO.	Code	Appearance	Ncm value
1	SDWRH-01		30 ~ 500

- How to assemble and use Torque wrench



- The Torque Wrench can be Changed to tighten clockwise or counterclockwise using the spring loaded direction pin.
- One hand should be used to hold the fixture remover in place when using the torque wrench to prevent loosening of the assembly.
The Fixture remover should be tightened Counterclockwise.
- The Assembly will be loosened if turned clockwise when using the torque wrench.
If the assembly loosens, retighten before using the torque wrench.

► Note ◀

- ▷ Please read the manual before using.
- ▷ Sterilize before using.
- ▷ Check the fixture size and compatibility list before using
- ▷ Use at least 40Ncm for fixture removal
- ▷ When connect the fixture remover and the tips, check the "V" sign into the part
- ▷ Use Screw only once if torquing up to 100Ncm

► Way to use ◀

1. Remove the Crown, abutment, and abutment screw to expose the implant



2. Tighten the appropriate sized remover screw into the implant fixture in a clockwise direction



3. Use the torque Wrench to Tighten the screw clockwise to 50–100Ncm using the small teardrop torsion bar



※ Follow the arrow to clockwise.

4. Use the adapter to combine the two parts of the fixture remover assembly

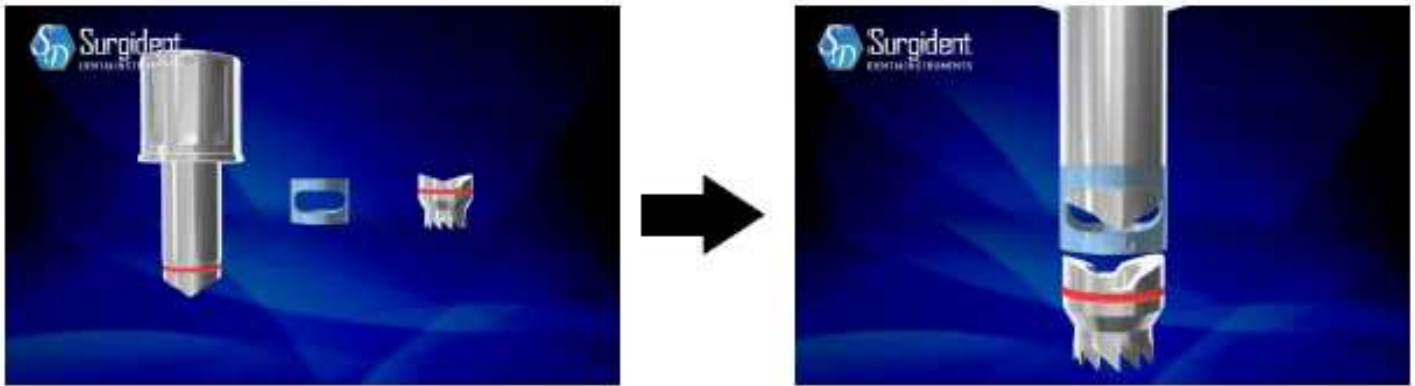

5. After insertion of the fixture remover, hand tighten counterclockwise



6. Using the torque wrench tighten the fixture remover counterclockwise to 250–450Ncm with the thick torsion bar



※ Follow the arrow to counterclockwise

7. Separate fixture from the screw

